

Type: M-13/M-14

Biological Monocular Microscope

CE

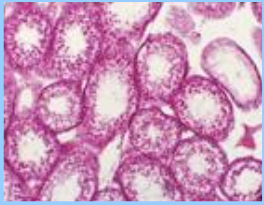

Our Biological Microscopes Type M-13 and M-14 are ideal for educational, medical and laboratory use. The M-13 and M-14 Microscopes have a metal and heavy duty body in combination with the robust type of building coverage allows a high-performance microscopy even under difficult conditions on-site or in laboratory.

These models have a good quality optical system supplied with three achromatic objectives (Type M 13) or four achromatic objectives (Type M 14). The microscopes have built-in illumination which could be adjusted. An additional mirror allows freely operate the microscopes in the field, in manufacturing areas.

Features:

- A good quality optical system with a good image.
- Comfortable operating with ergonomic structure.
- Illumination via built-in incandescent Lamp .
- Additional mirror for in the field application.
- Plain stage (Type M-103) or with attachable Mechanical Stage 110X120 mm / 60X30 mm; with slide clips (Type M-104)
- Achromatic objectives 4x, 10x and 40x (Type M-13) and additional 100x (Type M-14).

TECHNOLOGY

Specifications



		M-13	M-14
Stand	Durable metal stand	■	■
Viewing Head	Monocular Head, Inclined at 45°	■	■
Eyepiece	Wide Field Eyepiece WF10×/ 18	■	■
	Triple Nosepiece	■	
Nosepiece	Quadruple Nosepiece		■
	Achromatic Objective 4x, 10x, 40x	■	
Objective	Achromatic Objective 4x, 10x, 40x, 100x oil immersion		■
	Plain Stage size 130x120 mm with slide clips	■	
Stage	Attachable Mechanical Stage 110x120 mm / 60x30 mm; with slide clips		■
	Focusing system	Separate coarse and fine adjustment	■
Condenser	Single Lens with Disc Diaphragm	■	
	NA 1.25 Abbe Condenser with Iris Diaphragm		■
Filter	Blue Filter and Green Filter		■
	Built-in illumination, incandescent Lamp, adjustable brightness, 6V / 15W	■	■
Illumination	plan-concave mirror and mirror holder	■	■
	Mains	220-240 V / 50-650 Hz	■
Approval	CE, EN 50081-1		

■ standard □ optional

Article No.	Type	Description	
0.408.810	M-13	Monocular Microscope, plain stage, Achromatic objectives 4x, 10x, 40x	1 set
0.408.811	M-14	Monocular Microscope, X-Y attachable stage, Achromatic objectives 4x, 10x, 40x, 100x	1 set

Accessories:

0.408.980	LI-1	Bulb Incandescent Lamp 6V /15W 230 V	pcs.
0.408.990	Wd-1	Wooden case for M-13 & M-14	pcs.

		
Plain stage (M-13)	Attachable Mechanical Stage (M-14)	Mirror

**made
in
Germany**

SCO ENGINEERING GmbH
Auf der Heide 15
D- 37351 Dingelstädt
Federal Republic of Germany

Phone : +49 (36075) 439-306
Fax: +49 (36075) 439-308
Email: info@sco-tech.com
Internet: www.sco-tech.com



Order Information's:



Contact